

# ODU AUTOMOTIVE

DOCKING | HV | CHARGING

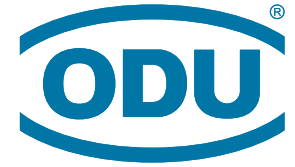

THE EV CONTACT SPECIALIST

[www.odu-automotive.com](http://www.odu-automotive.com)

# DOCKING

Like screw termination – just better!

## ODU DOCKING MATE<sup>®</sup> – THE SOLUTION FOR E-MOTORS

Modularization, miniaturization, and automation.

All these design challenges and the massive rise of power requirements make it necessary to fundamentally rethink the electrical connections on power units – without subsequently screwing.

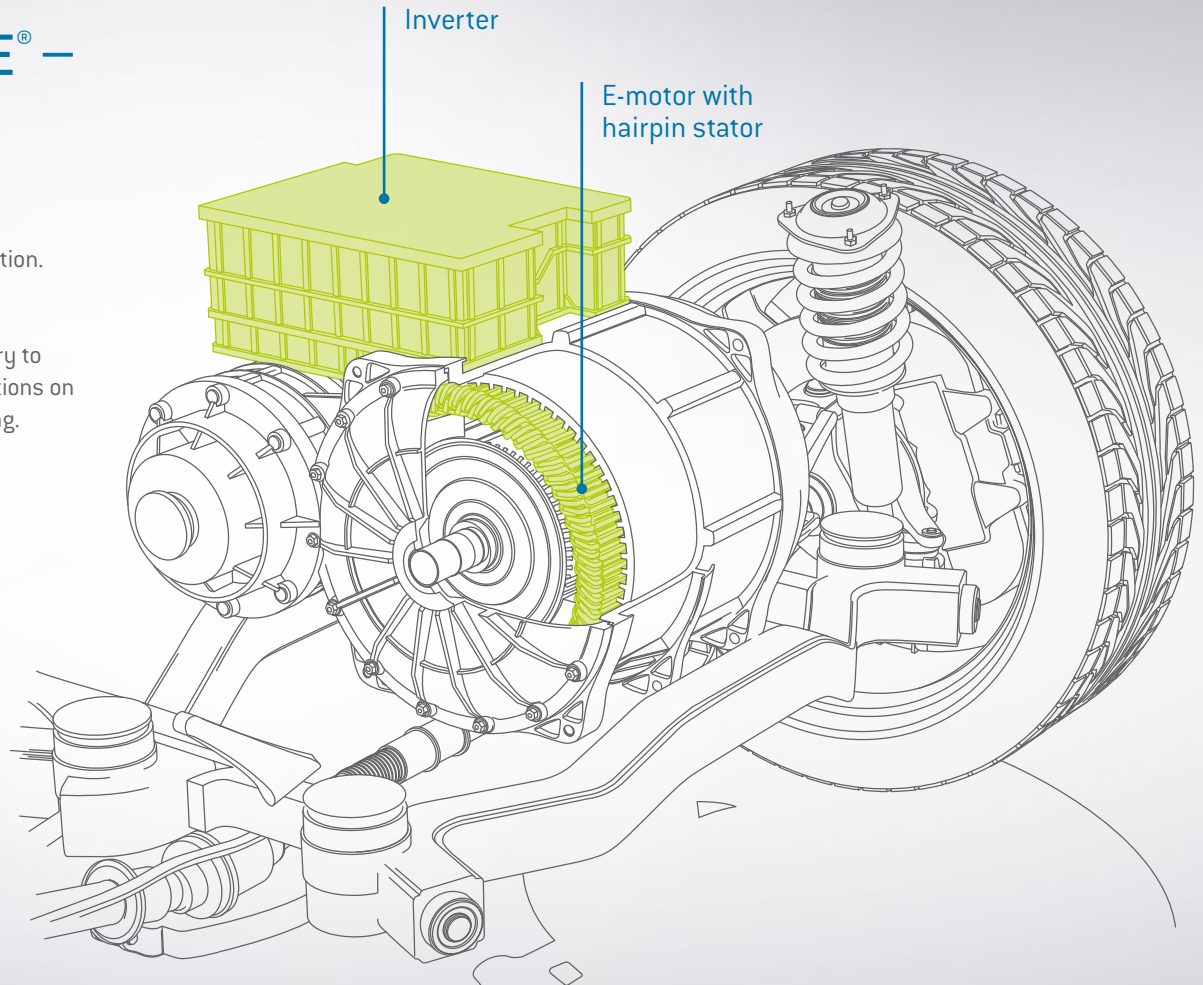

# TOLERANCE COMPENSATION

Multi-position interfaces are required at various points on the drivetrain. In some cases, wired connectors can be used – however, when connecting modules directly, a docking system is the better choice.

In particular, connections that include rigid busbars require a contact system that can precisely compensate for tolerances and thus allow automated assembly. The ODU DOCKING MATE® direct connector system is our answer to these challenges.

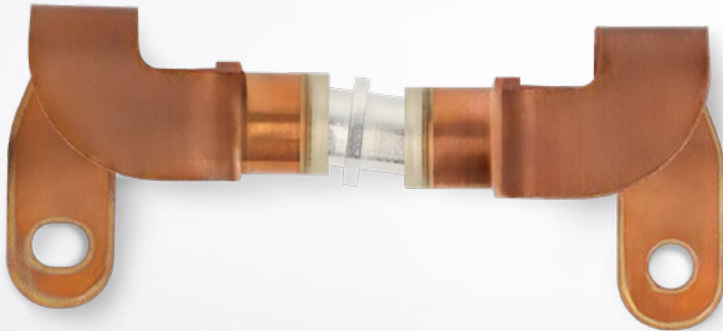

“The increasing integration of additional functions in electric drives necessitates a rethink with regard to the associated connector systems.”

## AT A GLANCE

- + Tolerance compensation of up to  $\pm 3$  mm
- + With sealing function in mated and unmated condition
- + Easy to adjust – even in tight spaces
- + Power and signal in a compact interface
- + Enables automated assembly processes

# DOCKING

Connectors for modular battery packs.

## ODU DOCKING MATE<sup>®</sup> – FOR COMMERCIAL AND INDUSTRIAL VEHICLES

The arrangement of modular battery packs varies for all-electric transport vehicles and can be adapted to specific needs.

Due to the modular design, each battery pack has a separate battery management system (BMS), that has to be integrated into the overall electric system.

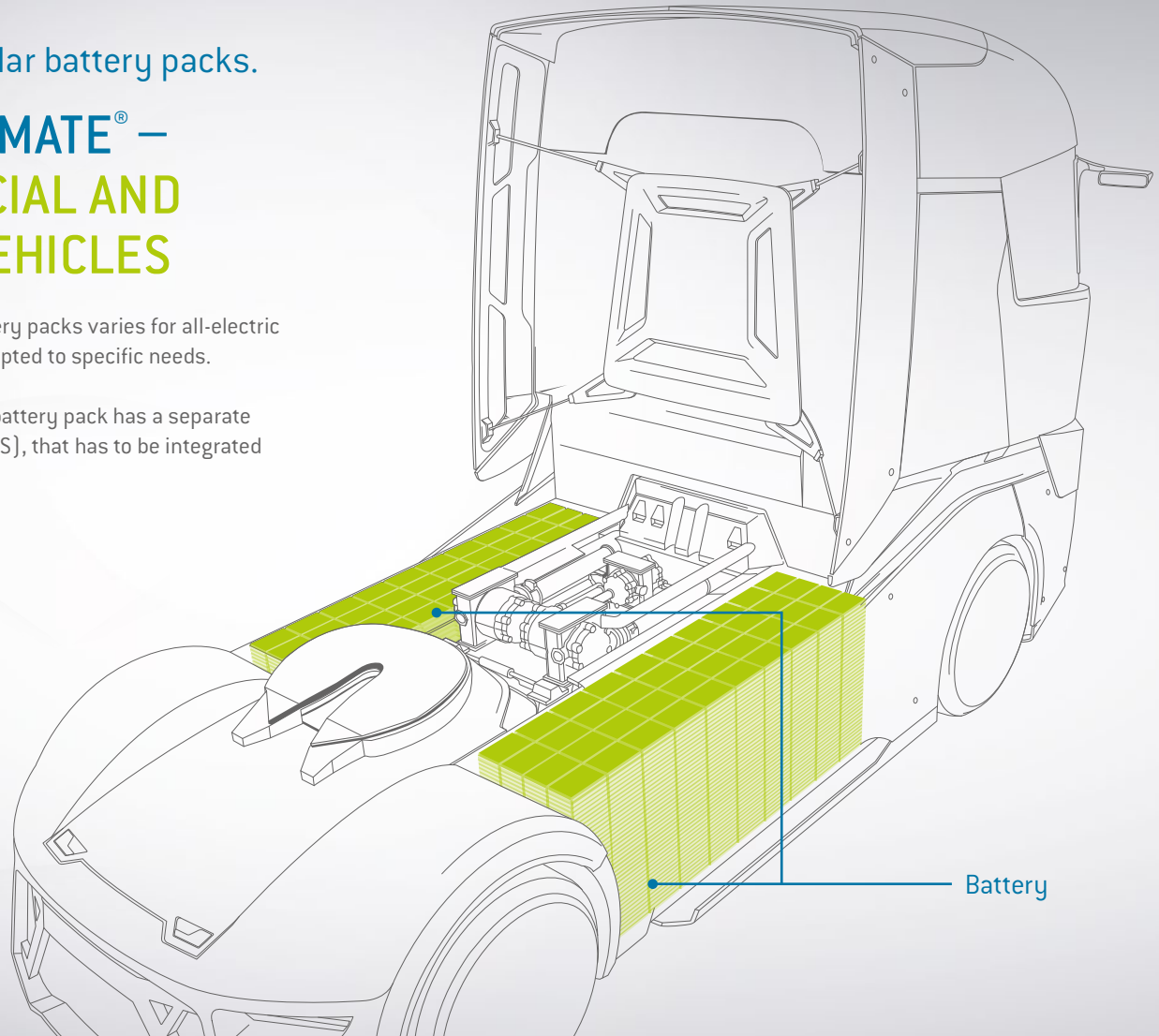

## ODU DOCKING MATE®

- + Can be plugged in blindly
- + Power and signal in a compact interface
- + No disturbing cable connections
- + Compensate tolerances

### INDUSTRIES THAT BENEFIT



Goods transport



Passenger transport



Construction vehicles



Agricultural vehicles

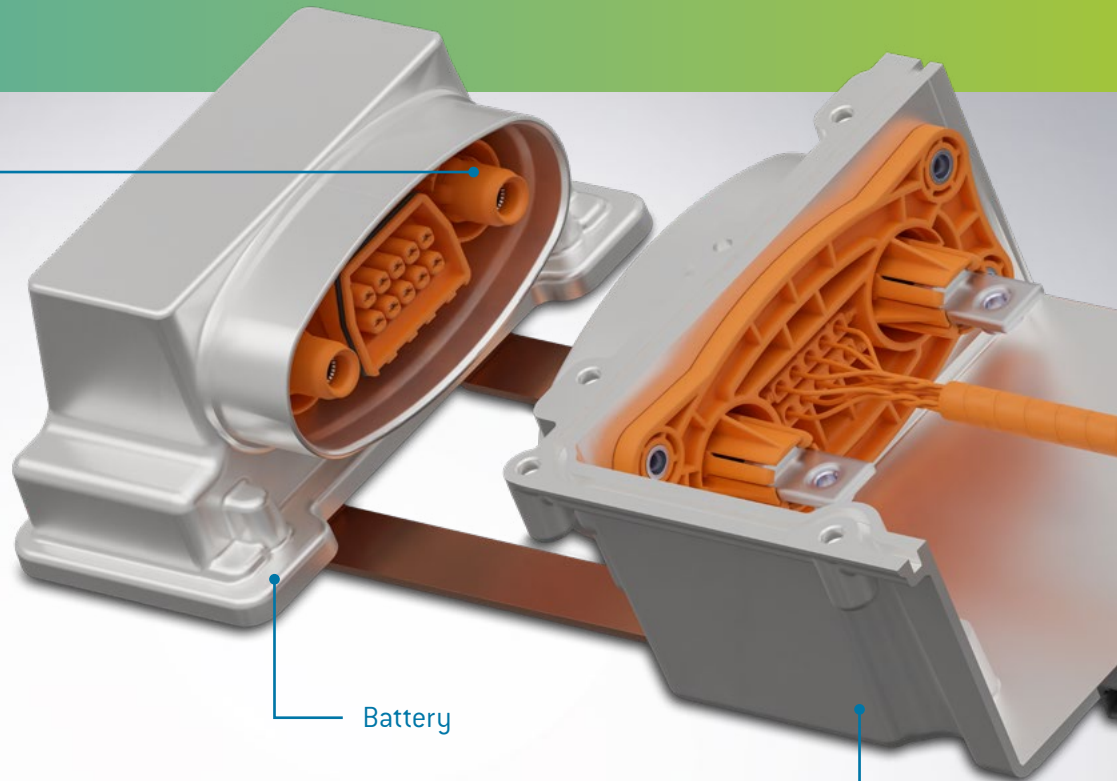

Battery

Battery Management System (BMS)

**TALK TO US!**

[engineering@odu-automotive.com](mailto:engineering@odu-automotive.com)

Always at full power

## CONTACT SYSTEMS FOR HIGH-CURRENT APPLICATIONS

Connectors that can transmit more power even at high ambient temperatures require a reliable and robust contact system. Besides being sturdy enough for high-current transmissions, these contact systems must also withstand challenging operating conditions – including strong vibrations in the vehicle.

Our contact technologies for HV applications perfectly meet these requirements and can also be easily adapted to our customers' needs.

“ New challenges are the ideal drivers for ongoing product development. ”



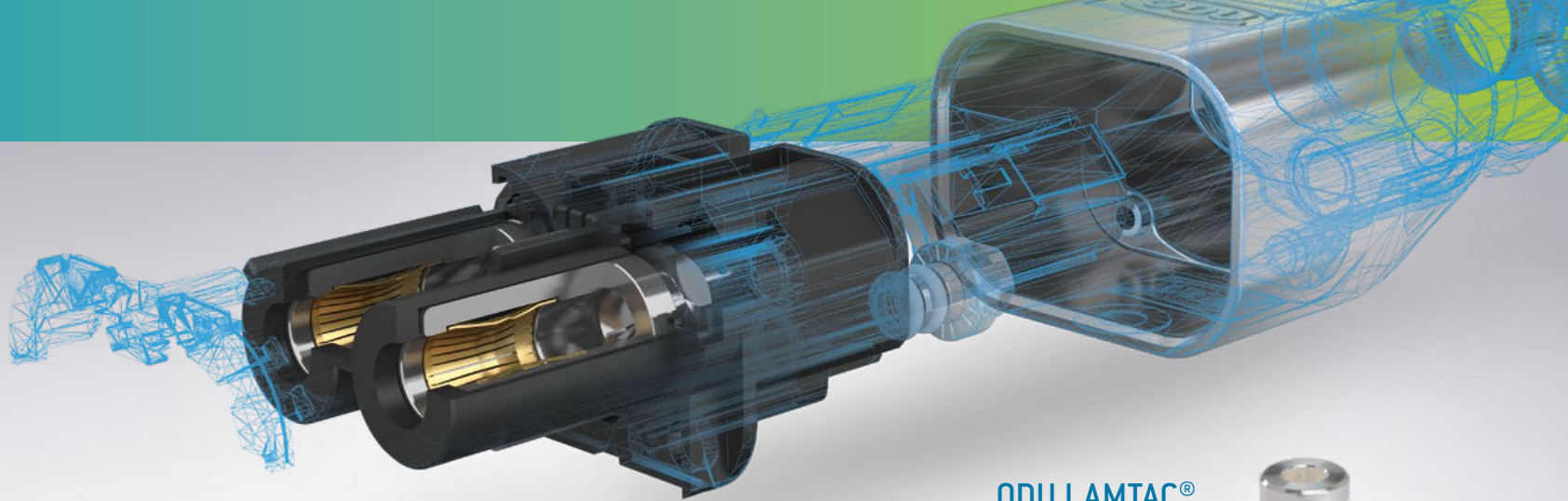

ODU LAMTAC®  
CLASSIC



ODU LAMTAC®  
FLEX



- + Extremely flexible contact design
- + Low and stable contact resistances
- + High number of contact points
- + Highly resistant to vibration and shock
- + Various solutions for cable assembly and connection

# CHARGING





## ODU CONTACTS FOR CHARGING APPLICATIONS

The reliable choice for charging cables and handles, vehicle inlets, wallboxes and adapters.

With both our ODU TURNTAC® and ODU STAMPTAC® series, our customers benefit from perfectly coordinated in-house processes. From consulting to development to testing, we coordinate every step under one roof. For maximum efficiency – and minimal “charging losses”.



ODU TURNTAC®



ODU STAMPTAC®

# CHARGING



## THE EV CONTACT SPECIALIST

ODU specializes in realizing high-performance and particularly durable charging contacts.

ODU TURNTAC® and ODU STAMPTAC® are proprietary contacting solutions for all common and upcoming standards, which perfectly combine the requirements of both manufacturers and users.



# IEC 62196 (VDE 0623-5)

## Type 2



## AC – ALTERNATING CURRENT

Position	Nominal values	Termination cross section	Number of contacts / diameter
L1, L2, L3, N (PE)	3.7 kW · 230 V AC · 16 A 11 kW · 400 V AC · 16 A	2.5 mm <sup>2</sup>	5 contacts · Ø 6 mm
	7.4 kW · 230 V AC · 32 A 22 kW · 400 V AC · 32 A	6 mm <sup>2</sup>	
CP, PP	30 V DC · 2 A	0.5 mm <sup>2</sup>	2 contacts · Ø 3 mm

## CCS Combo 2

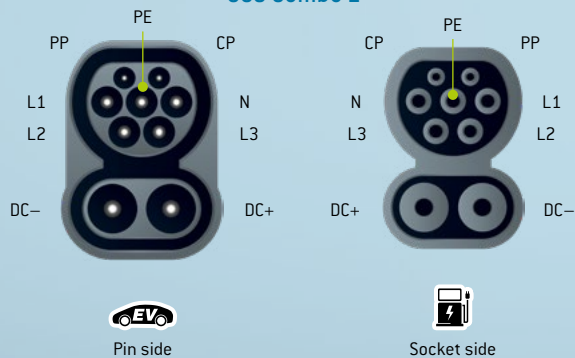

## DC – DIRECT CURRENT

Position	Nominal values	Termination cross section	Number of contacts / diameter
DC+, DC-	200 kW · 1,000 V DC · 200 A 250 kW · 1,000 V DC · 250 A (up to 500 kW)	50 mm <sup>2</sup> 70 mm <sup>2</sup>	2 contacts · Ø 8 mm
PE	–	25 mm <sup>2</sup>	1 contact · Ø 6 mm



## AC – ALTERNATING CURRENT<sup>1</sup>

<sup>1</sup> For the AC values, please refer to the table above.

# CHARGING



SAE J3400

Type 1



## AC – ALTERNATING CURRENT

Position	Nominal values	Termination cross section	Number of contacts / diameter
L1, L2 / N	7.7 kW · 240 V AC · 32 A 11.5 kW · 240 V AC · 48 A 19.2 kW · 240 V AC · 80 A	AWG 10 AWG 8 AWG 6	2 contacts · Ø 9 mm
PE	–	AWG 10 + AWG 18 AWG 8 + AWG 18 AWG 6 + AWG 18	1 contact · Ø 3.6 mm
CP / PP	30 V DC · 2 A	AWG 18 2 x AWG 18	2 contacts · Ø 1.6 mm



## DC – DIRECT CURRENT<sup>1</sup>

Position	Nominal values	Termination cross section	Number of contacts / diameter
DC+, DC-	200 kW · 1,000 V DC · 200 A (max. 400 A) <sup>2</sup>	AWG 1	2 contacts · Ø 9 mm



<sup>1</sup> For the other contacts, please refer to the table above and the corresponding standard for the PE termination cross-section.

<sup>2</sup> Maximum instantaneous current. Duration of maximum current is a function of ambient temperature and vehicle inlet capabilities.

This overview shows a selection of the most common charging interfaces. For more information please contact: [engineering@odu-automotive.com](mailto:engineering@odu-automotive.com)



## SAE J1772

### Type 1



## AC – ALTERNATING CURRENT

Position	Nominal values	Termination cross section	Number of contacts / diameter
L1, L2 / N	7.7 kW · 240 V AC · 32 A 11.5 kW · 240 V AC · 48 A	AWG 10 AWG 8	2 contacts · Ø 3.6 mm
PE	–	AWG 10 AWG 8	1 contact · Ø 2.8 mm
CP, CS / PP	30 V DC · 2 A	AWG 22	2 contacts · Ø 1.5 mm

### CCS Combo 1



## DC – DIRECT CURRENT



## AC – ALTERNATING CURRENT<sup>1</sup>

Position	Nominal values	Termination cross section	Number of contacts / diameter
DC+, DC-	125 kW · 1,000 V DC · 125 A 200 kW · 1,000 V DC · 200 A 250 kW · 1,000 V DC · 250 A	35 mm <sup>2</sup> * 50 mm <sup>2</sup> 70 mm <sup>2</sup> * [AWG cable types on request]	2 contacts · Ø 8 mm

<sup>1</sup> For the AC values, please refer to the table above and the corresponding standard for the PE termination cross-section.

\* on request

# CHARGING



GB / T 20234\*



## AC – ALTERNATING CURRENT

Position	Nominal values	Termination cross section	Number of contacts / diameter
L1, L2, L3, N (PE)	3.7 kW · 230 V AC · 16 A 11 kW · 400 V AC · 16 A	2.5 mm <sup>2</sup>	5 contacts · Ø 6 mm
	7.4 kW · 230 V AC · 32 A 22 kW · 400 V AC · 32 A	6 mm <sup>2</sup>	
CC, CP	30 V DC · 2 A	0.5 mm <sup>2</sup>	2 contacts · Ø 3 mm



## DC – DIRECT CURRENT

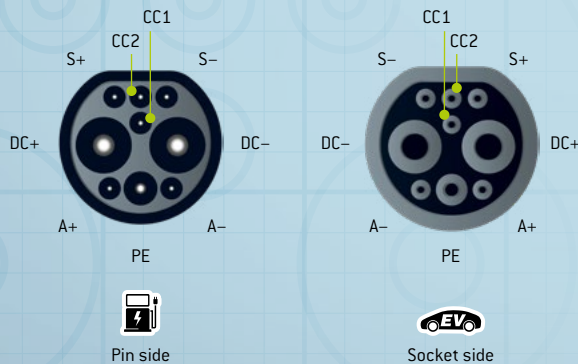

Position	Nominal values	Termination cross section	Number of contacts / diameter
DC+, DC-	80 kW · 1,000 V DC · 80 A 125 kW · 1,000 V DC · 125 A 250 kW · 1,000 V DC · 250 A	25 mm <sup>2</sup> 35 mm <sup>2</sup> 70 mm <sup>2</sup>	2 contacts · Ø 12 mm
CC1, CC2, S+, S-	30 V DC · 2 A	0.5 mm <sup>2</sup>	6 contacts · Ø 3 mm
A+, A-	30 V DC · 20 A	2.5 mm <sup>2</sup>	
PE	–	25 mm <sup>2</sup>	1 contact · Ø 6 mm

\* on request



## ODU ADAPTER

Complete solutions for combining different charging standards.



Type 1 – NACS Adapter



GB/T – ChaoJi Adapter

# IN-HOUSE COMPETENCE



## ADVICE PRODUCTION SUPPORT

All from one source

At ODU, we develop customized solutions based on our vast pool of know-how and expertise.

Our decisive advantage? Every single step of the production and development process takes place in-house. From consulting to final inspection, we ensure that our connections meet the customer's requirements in every respect – no matter how challenging and customized they may be.



## Quality and efficiency in every detail

In addition to metal processing, our range of manufacturing options also includes a wide variety of plastic processing methods, numerous electroplating and chemical coating processes, as well as our in-house mold and tool shop.

With 80 % in-house manufacturing, we can implement changes flexibly and quickly during product development. Lastly, our state-of-the-art equipment ensures maximum cost efficiency and quality in series production.

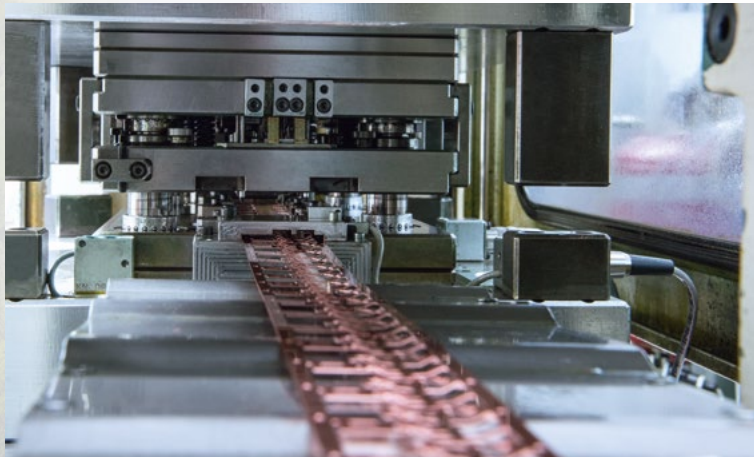

## Surface engineering

As a leading supplier of high-quality coating systems, we integrate surface engineering aspects into all development and production steps from the outset.

Barrel, vibrobot, rack, or conveyor systems are used for coating procedures – these are selected according to the specific product requirements.



# IN-HOUSE COMPETENCE

## Measure, test, understand, and control

State-of-the-art test procedures ensure maximum reliability even under the most challenging conditions:

- + Electrical and mechanical testing methods
- + Thermal inspections and environmental simulations
- + Material selection and inspection

By developing products and creating reliable simulation forecasts at the same time, we can quickly design a solution that is cost-effective for you.

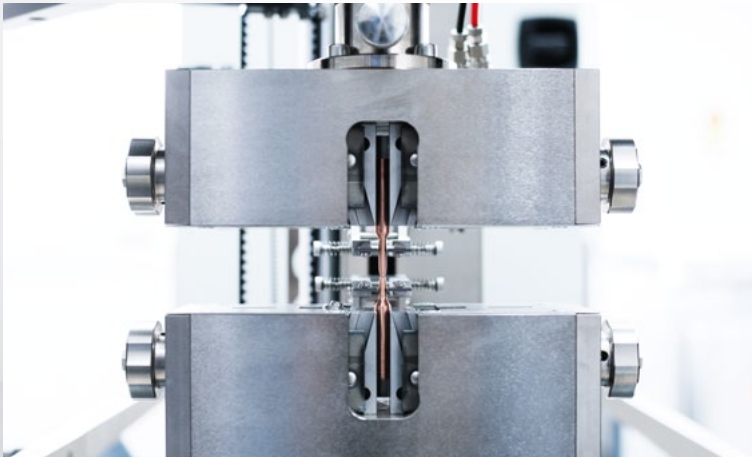

## Assembly

To ensure economical production for our customers, we place particular emphasis on efficiency and quality in our assembly processes. Our proprietary, fully automated assembly machines are tailored to the end product and thus ensure cost-optimized solutions in series production.



## The right termination technology for maximum performance

The termination area of a contact is often underestimated in terms of its impact on the performance and functionality of the overall connector system. Just like the contact area itself, it must guarantee constant transmission – even under extreme conditions.

ODU offers a wide range of technologies such as:

- + Crimping
- + Screws
- + Ultrasonic and laser welding



“ Knowledge connects.  
Experience creates trust.”



Printed on certified  
recycled paper.

All dimensions are in mm.  
Some figures are for illustrative purposes only. Subject to change  
without notice. Errors and omissions excepted. We reserve the right to  
change our products and their technical specifications at any time in  
the interest of technical improvement. This publication supersedes all  
prior publications.

THE EV CONTACT SPECIALIST / B / 0924 / EN

This publication is also available as a PDF file that can be downloaded  
from [www.odu-automotive.com](http://www.odu-automotive.com)